

Name : _____

Grade : VI

Subject : Mathematics

Chapter: 14 Practical Geometry

Objective Type Questions

1 Marks

I. Multiple choice questions

1. The instrument in the geometry box having the shape of a triangle is called a
a. Protractor b. Compasses c. Divider d. set-square
2. The instrument to measure an angle is a
a. Ruler b. Protractor c. Divider d. compasses
3. The instrument to draw a circle is
a. Ruler b. Protractor c. Divider d. compasses
4. Two lines are perpendicular, if they intersect each other at
a. Acute angle b. right angle c. obtuse angle d. none of these
5. Perpendicular bisector of a line segment
a. Is perpendicular to it b. divides it into two equal parts
c. Both (a) and (b) are true d. None of the above
6. Which of the following angles can be drawn with the help of a compasses?
a. 20° b. 40° c. 60° d. 80°

7. In the given figure, point B lies

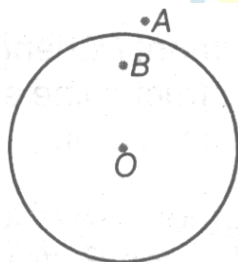

- a. Interior b. Exterior c. both (a) and (b) d. None of these
8. Draw any line segment \overline{PQ} . Take any point R not on it. Through R, draw a perpendicular to \overline{PQ} . Which of the following figure satisfy the above condition?

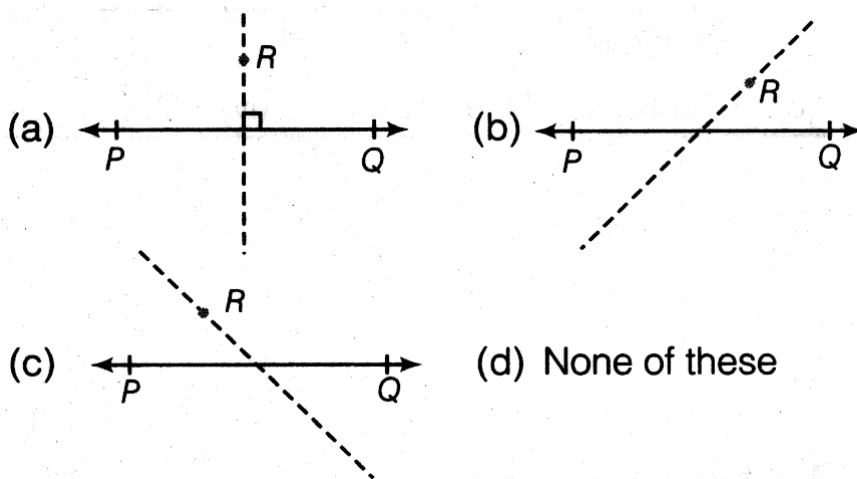

9. If the diameter of a circle is 16 cm, then what will be its radius?

- a. 16 cm b. 10 cm c. 8 cm d. None of these

10. Draw any line segment AB. Take any point C on it. Through C, draw a perpendicular to AB, which of the following figure satisfies the above condition?

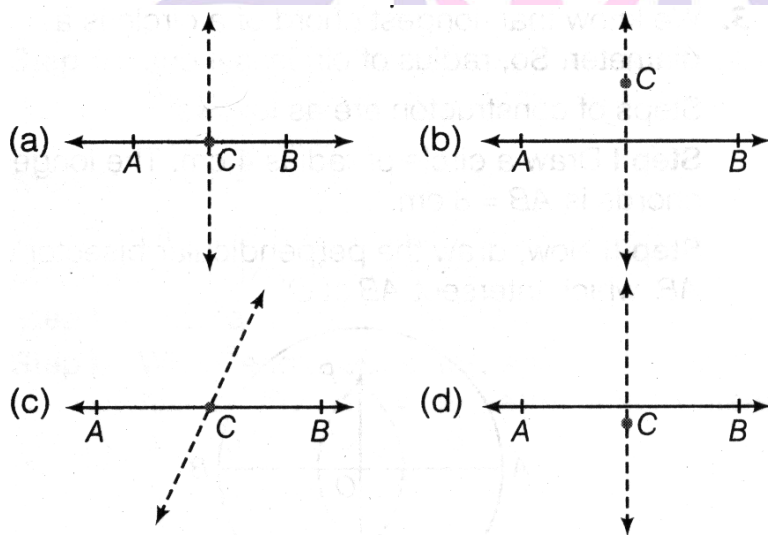

1. (d)	2. (b)	3. (d)	4. (b)	5. (c)	6. (c)	7. (a)	8. (a)	9. (c)	10. (a)
--------	--------	--------	--------	--------	--------	--------	--------	--------	---------

II. Multiple choice questions

- The instrument to measure an angle is a:
 - Ruler
 - Protractor
 - Divider
 - Compasses
- The instrument to draw a circle is :
 - Ruler
 - Protractor
 - Divider
 - Compasses
- Number of set squares in the geometry box is:
 - 0
 - 1
 - 2
 - 3

4. The instrument in the geometry box having the shape of a triangle is called a :
 a. Protractor b. Compasses c. Divider d. Set-square
5. Which of the following has no end points:
 a. A line segment b. a ray c. a line d. none of these
6. Which of the following has one end points:
 a. A line segment b. a ray c. a line d. none of these
7. Which of the following has two end points:
 a. A line segment b. a ray c. a line d. none of these
8. Two planes intersect:
 a. At a point b. in a line c. in a plane d. none of these
9. $\frac{3}{2}$ right angles = _____.
 a. 115° b. 135° c. 230° d. 270°
10. Where does the vertex of an angle lie?
 a. In its interior b. in its exterior c. on the angle d. None of these
11. An angle measuring 270° is:
 a. An obtuse b. an acute angle c. a straight line d. a reflex angle

1. (b)	2. (d)	3. (c)	4. (d)	5. (c)	6. (b)
7. (a)	8. (b)	9. (b)	10. (c)	11. (d)	

I. Fill in the blanks

1. The common properties in the two set-squares of a geometry box are that they have a _____ angle and they are of the shape of a _____.
2. A chord of a circle is a line segment with its ends point _____.
3. A radius of a circle is a line segment with one end at the _____ and the other end _____.
4. A diameter of a circle is the _____ chord of the circle.
5. A diameter of a circle is a chord that _____ through the centre.

6. A chord of a circle divide the circle into two parts, where each part is called an _____ of the circle.

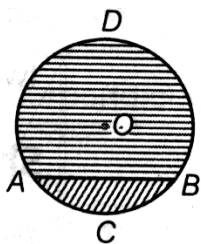

7. Circles, which have the same centre and different radii are called _____ circle.

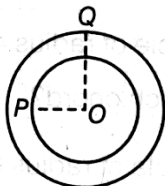

8. An angle having degree measure as 90° is called _____.

9. The centre of the semi-circle (protractor) is called _____.

10. The line of symmetry of a line segment is the _____ bisector of line segment.

1. right, triangle	2. circumference	3. centre, on the circle	4. longest	5. passes
6. segment	7. concentric	8. right angle	9. central point	10. perpendicular

II. Fill in the blanks

- Two line intersecting at right angles are known _____.
- Set squares are used to draw _____ and _____.
- _____ circle can be drawn through three non-collinear points.
- _____ and _____ perpendicular can be drawn to a line at a point on it.
- To draw the axis of symmetry of an angle its _____.
- A line has _____ end point.
- A ray has _____ end point.
- 0° _____ acute angle _____ $90^\circ <$ obtuse angle $< 180^\circ$.
- The standard unit of measuring an angle is _____.

1. Perpendicular lines	2. Perpendicular and parallel lines	3. only one
------------------------	-------------------------------------	-------------

4. One and only one	5. Angle bisector	6. No
7. One	8. $<$, $>$	9. Degree

I. Match the followings

1. Consider the figure, then match the items of Column A in Column B with their respective value.

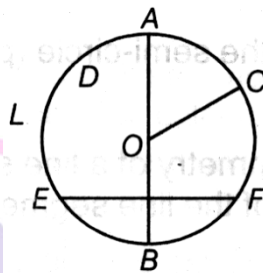

Column A	Column B
a. The radius of the circle	i. D
b. Segment of the circle	ii. AOCA
c. The point in the interior of the circle	iii. EBFE
d. The sector of the circle.	iv. \overline{OC}

a. (iv)	b. (iii)	c. (i)	d. (ii)
---------	----------	--------	---------

II. Match the followings

Column A	Column B
a. Angle bisector	i. To measure length of a line segment
b. Perpendicular	ii. To construct and measure
c. Divider	iii. To construct perpendicular and parallel lines
d. Protractor	iv. To find axis of symmetry of the angle
e. Set square	v. To construct and measure length of line segment
f. Ruler	vi. To find axis of symmetry of a line segment

a. (iv)	b. (vi)	c. (i)	d. (ii)	e. (iii)	f. (v)
---------	---------	--------	---------	----------	--------

I. True or False

1. It is possible to draw two bisectors of a given angles.
2. Infinitely many perpendiculars can be drawn to a given rays.
3. With ruler and compasses, we can bisect any given line segment.
4. Only one perpendicular bisector can be drawn to a given line segment.
5. Two perpendiculars can be drawn to a given line from a point not lying on it.
6. With a given centre and a given radius, only one circle can be drawn.
7. Using only the two set-squares of the geometry box, an angle of 40° can be drawn.
8. Using only two set-squares of the geometry box, an angle of 15° can be drawn.
9. In the given figure, point A lies interior of the circle.

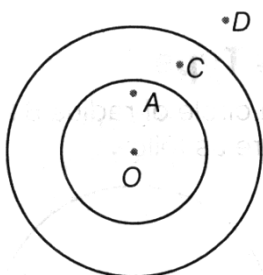

10. In the given figure, the diameter of the circle is GF.

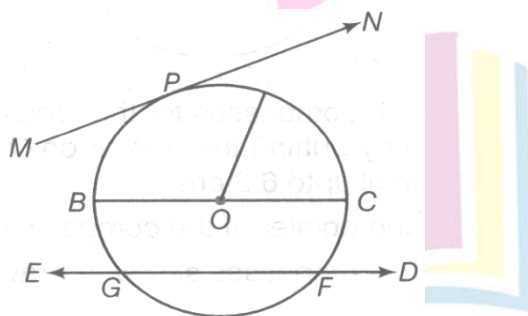

1. False	2. True	3. True	4. True	5. False
6. True	7. False	8. True	9. True	10. False

II. True or False

1. With ruler and compasses, we can bisect any given line segment.
2. Only one perpendicular bisector can be drawn to a given line segment.
3. Two perpendiculars can be drawn to a given line from a point not lying on it.
4. With a given centre and a given radius, only one circle can be drawn.
5. Using only the two set-squares of the geometry box, an angle of 40° can be drawn.
6. Using only the two set-squares of the geometry box, an angle of 15° can be drawn.
7. It is possible to draw two bisectors of a given angle.
8. If two line segments do not intersect, they are parallel.
9. If two rays do not intersect, they are parallel.
10. If two lines do not meet even when produced, they are called parallel lines.
11. Two parallel lines are everywhere the same distance apart.
12. A ray has a finite length.
13. Ray \vec{A} is the same as ray $\left(22\frac{1}{2}\right)^\circ$.

1. True	2. True	3. False	4. True	5. False	6. True	7. False	8. False
9. False	10. True	11. True	12. False	13. False			

I. Very Short Answer Type Questions

1. **What is a circle?**

Circle is the set of those point which are at equal distance from a fixed point.

2. **What is the smallest unit marked in the scale?**

The smallest unit marked in the scale is mm.

3. **What is the largest chord of a circle?**

Diameter of a circle is the largest chord.

4. **How many set-squares are there in a geometry box?**

There are two set-squares.

5. **What measures of angle are marked on protractor?**

The measurements of angle that are marked on protractor are 0° to 180°

6. What do you mean by angle bisector of an angle?

Angle bisector of an angle divides the angle into equal angles.

7. Find the angle between perpendicular lines.

Two lines are said to be perpendicular, if they intersect each other at right angle. So, angle between them is 90° .

8. An angle bisector of an angle divided it into angles of 35° each, find the angle.

The required angle = $35^\circ + 35^\circ = 70^\circ$

9. Is angle bisector of an angle lies in its exterior or interior of an angle?

Angle bisector of an angle is a line, so it can be extended in interior as well as exterior of an angle.

10. What is the measure of an angle whose bisector makes an angle of a right angle?

The required angle is 180° .

11. Name the tool used to compare the lengths of line segment without measuring them.

Divider.

I. Short Answer Type Questions

1. Construct a circle of radius 6.2 cm.

To construct a circle of radius 6.2 cm, steps of construction are as follows:

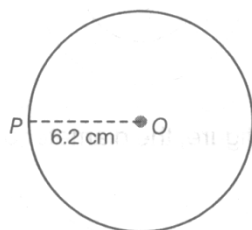

- Open the compasses for the required radius 6.2 cm by putting the pointer on O and opening the pencil upto 6.2 cm.
- Place the pointer of the compasses at O.
- Turn the compasses slowly to draw the circle.

2. Given, a circle of radius 3.1 cm, mark points A, B and C such that

- i. A is on the circle.
- ii. B is in the interior of the circle.
- iii. C is in the exterior of the circle.

The required circles, are given below:

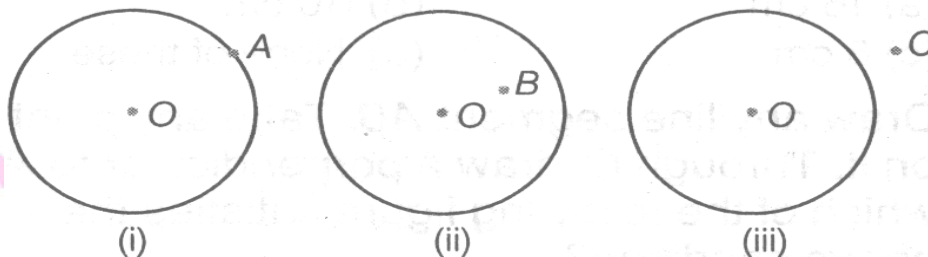

3. The longest chord of a circle is 8 cm. how will you find the centre of the circle?

We know that, longest chord of a circle is a diameter. So, radius of circle is 4 cm.

Steps of construction are as follows:

Step I Draw a circle of radius 4 cm. The longest chords is $AB = 8$ cm.

Step II Now, draw the perpendicular bisector of AB, which intersect AB at O.

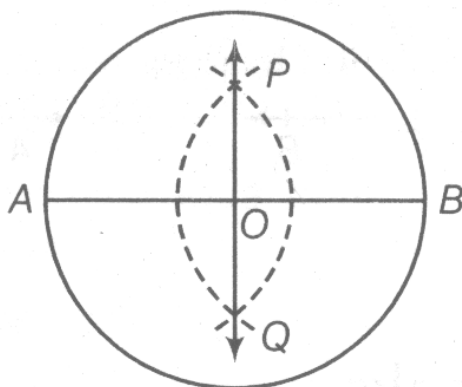

Step III 'O' is the centre of the circle.

4. Given, a circle of $r = 3$ cm. draw two perpendicular diameters AB and CD. Join the end points of the diameters. State the name of the diameters. State the name of the quadrilateral so formed.

Given, radius of circle is 3 cm.

Steps of construction are as following:

Step I Draw a circle of radius 3 cm.

Step II Draw two perpendicular diameters AB and CD.

Step III Join A and D, D and B, B and C and A and C. Thus, quadrilateral ABCD is a square.

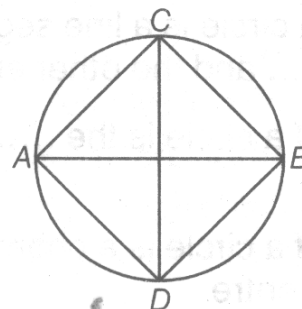

5. Draw a line segment PQ length 4 cm using a ruler. Also, construct a line segment of 4 cm using ruler and compass.

Step of construction are as following:

Step I Draw \overline{PQ} of length 4 cm.



Step II Draw a line l and mark a point R on it.

Step III Open the compasses equal to \overline{PQ} .

Step IV Keeping the same opening. Place the pointer on R and mark a point S on l . Thus, \overline{RS} is equal to \overline{PQ} .



6. Draw a line segment \overline{AB} of length 5 cm. take a point P on it. Through P, draw a perpendicular to AB. (using ruler and compasses).

Step of construction are as follows:

Step I Draw a line segment \overline{AB} of length 5 cm.

Step II Take a point P and place the pointer of compasses at P draw an arc that it intersect \overline{AB} at X and Y.

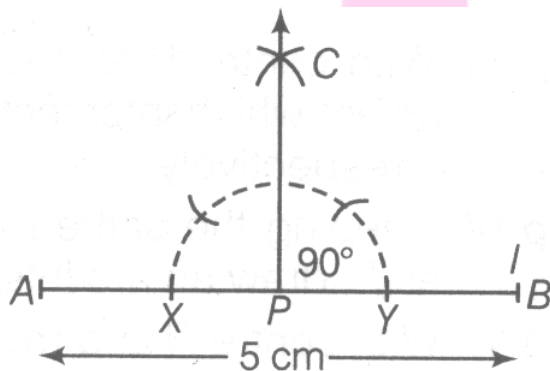

Step III With X and Y as centres and radius greater than PX, draw two arcs such that they intersect at C.

Step IV Join CP. Thus, $\overline{CP} \perp \overline{AB}$.

7. Draw PQ of length 7 cm and find its axis of symmetry.

We know that, perpendicular bisector of a line segment is its axis of symmetry.

Step I Draw a line segment $\overline{PQ} = 7$ cm.

Step II With P and Q as centres and radius more than half of PQ, draw two arcs which intersect each other at A and B.

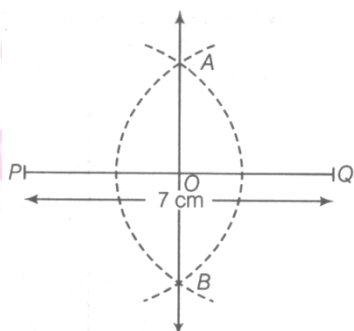

Step III Join A and B.

Thus, AB is the axis of symmetry of \overline{PQ} .

8. How will you construct a $22\frac{1}{2}^\circ$ angle?

Steps of construction are as follows:

Step I Construct an angle of 90° . i.e. $\angle POQ = 90^\circ$.

Step II Draw OR, the angle bisector of $\angle POQ$, such that

$$\frac{1}{2} \angle POQ = \frac{1}{2} (90^\circ) = 45^\circ$$

$$\therefore \angle POR = 45^\circ$$

Step III Now, draw OS, the angle bisector of

$$\angle POR = \frac{1}{2} \angle POR = \frac{1}{2} (45^\circ) = 22\frac{1}{2}^\circ$$

$$\text{i.e. } \angle POS = 22\frac{1}{2}^\circ$$

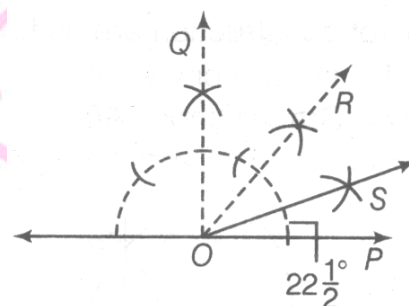

9. Refer to the figure given below and answer the following.

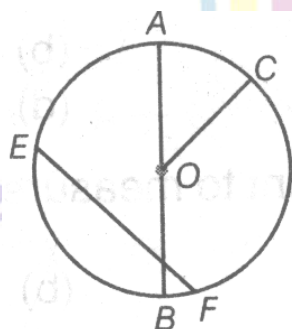

a. Name any diameter of the circle.

- b. Name any radius of the circle.
- c. Name the chord of the circle.
- d. What is the centre of the given circle?
 - a. Diameter of circle is \overline{AB} .
 - b. Radius of the circle is \overline{OA} , \overline{OB} and \overline{OC} .
 - c. The chord of the circle are \overline{EF} and \overline{AB} .
 - d. Centre of circle is 'O'.

10. How will you construct at 90° angle?

Construct a perpendicular to a line from a point on it.

Here, $\angle PAR = 90^\circ$

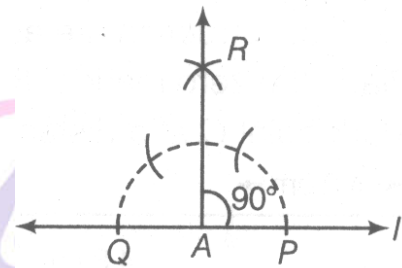

II. Short Answer Type Questions

1. Draw the images of point A and B in line l of figure and name them as 'A' and 'B', respectively. Measure AB and A' B'. Are they equal?

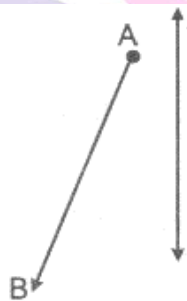

Yes, they are equal because by the rule of reflection of symmetry, the image of points A and B in the line (l) is the point A' and B' and both are equal in length. Lines are measured by the help of ruler.

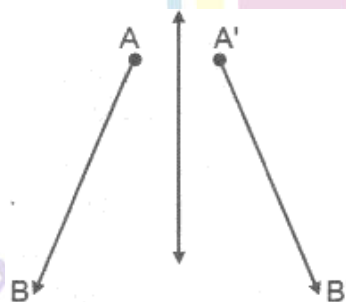

2. Draw a line segment of length 6 cm. Construct its perpendicular bisector. Measure the two parts of the line segment.

To draw a perpendicular bisector, we use following steps of construction.

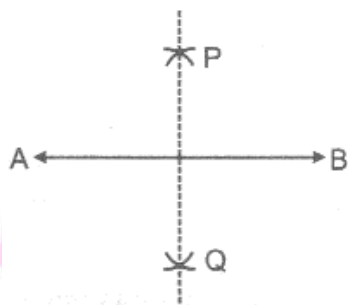

Step I : Firstly, we draw a line segment AB of length 6 cm.

Step II : With A and B as centre, more than half of the length AB draw arcs which intersect at points P and Q.

Step III : Join PQ, thus PQ is perpendicular to line segment AB.

Step IV : Measure the two parts of line segments with the help of ruler, it comes out to be 3 cm each.

3. Bisect a straight angle, using ruler and compasses. Measure each part.

Step I : Firstly, draw a line a line of any length say AB.

Step II : With P as centre, draw an arc which bisects the line at X and Y.

Step III : With X and Y as centers, draw two arcs which cut each other at Q.

Step IV : By the help of protractor, the measure of the angle is 90° .

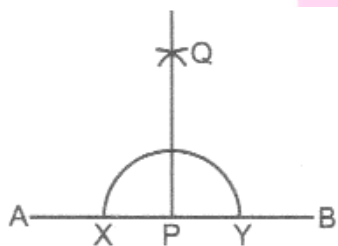

4. Bisect $\angle XYZ$ in figure given below:

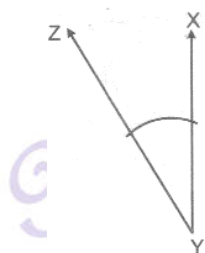

Ans:

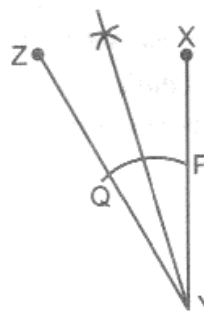

In the given figure, firstly cut the arc by compasses with point P and Q as centre P. and bisect as the shown in figure.

III. Short Answer Type Questions

1. Draw a line segment of length 10 cm. divide it into four equal parts. Measure each of these parts

To draw a line segment, we use following steps of construction

Step I : Firstly, we draw a line segment (AB) of length 10 cm.

Step II : By the help of compasses and ruler bisect the line segment and join both the points with line segment.

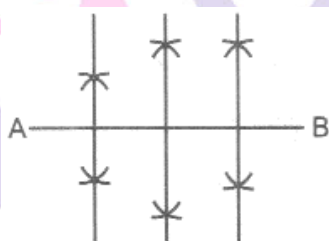

Step III : By the help of bisector of the line segment either side of line is also bisected by the ruler and compasses.

Step IV : Both bisector points of either side is joined.

Step V : By the help of ruler, we measure the each part of bisected line segment and each part is measured of length 2.5 cm.

2. Draw a line segment of length 7 cm. Draw its perpendicular bisector, using ruler and compasses.

To draw a perpendicular bisector of line segment of length 7 cm. We use the following steps of construction:

Step I : Firstly, draw a line segment \overline{AB} of length 7 cm.

Step II : With A as centre, using compasses, draw a circle.

The radius of circle should be more than half the length of \overline{AB} .

Step III : With the same radius with B as centre draw another circle using compasses.

Let it cut the previous circle at C and D.

Step IV : Join CD. It cuts \overline{AB} at O.

Use your divider to verify that O is the mid-point of \overline{AB} . Also, verify that $\angle COA$ and $\angle COB$ are right angles.

Therefore, \overline{CD} is the perpendicular bisector of \overline{AB} .

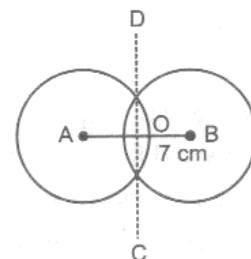

3. Draw an angle of 65° and draw an angle equal to this angle, using ruler and compasses.

Here, are the steps of construction.

Step I : Firstly, draw an angle of 65° , by using protractor.

Step II : Draw a line segment AB of any length.

Step III : Place the pointer at point A and cut an arc with reference point.

Step IV : Join the cut arc at point A.

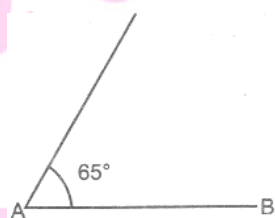

Hence, the given angle is of 65° .

4. Draw a line segment of length 6.5 cm and divide it into four equal parts, using ruler and compasses.

Here, are the steps of construction:

Step I : Firstly, draw a line segment AB of length 6.5 cm.

Step II : Place the compasses pointer at points A and B and cut the arcs at point P and Q. Join PQ and it is the bisector of line segment AB.

Step III : The either sides of bisector length is also bisected by the help of ruler and compasses.

Step IV : Join the arc points.

Step V : Hence, the line segment AB is divided into four equal parts by using ruler and compasses.

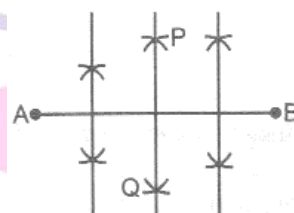

IV. Short Answer Type Questions

1. Fill in the blanks

- The line of symmetry of a line segment is the _____ bisector of the line segment.
- The common properties in the two set-square of a geometry box are that they have a _____ angle and they are of the shape of a _____.
- A straight angle equals _____ right angles.

i. perpendicular	ii. right, triangle	iii. two
------------------	---------------------	----------

2. Draw a circle of radius 3.2 cm

Step of construction:

Step 1 : Open the compasses for the radius of 3.2 cm.

Step 2 : Mark a point O on the paper with a sharp pencil.

Step 3 : Place the pointer of the compasses on O .

Step 4 : Turn the compasses slowly to draw the circle. Complete the movement around in one instant.

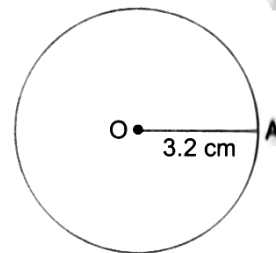

3. Draw a line segment of length 7.3 cm using a ruler.

Step of construction:



Step 1 : Mark a point A on the plane of the paper.

Step 2 : Place the zero mark of the ruler at point A .

Step 3 : Mark a point B against the mark on the ruler which indicates 7.3 cm.

Step 4 : Join A and B . \overline{AB} is the required line segment.

4. Construct a line segment of length 5.6 cm using ruler and compasses.

Steps of construction:

Step 1 : Draw a line l . Mark a point A on this line.

Step 2 : Place the compasses pointer on the zero mark of the ruler. Open it to place the pencil point upto 5.6 cm mark.

Step 3 : Without changing the opening of the compasses, place the pointer on A and swing an arc to cut l at B .

Step 4 : \overline{AB} is a line segment of required length.



5. Draw any line segment \overline{PQ} . Without measuring \overline{PQ} , construct a copy of \overline{PQ} . S

Steps of construction:

Step 1 : Draw \overline{PQ} whose length is not known.

Step 2 : Fix the compasses pointer on P and the pencil end on Q . This gives the length of \overline{PQ} .

Step 3 : Draw any line l . Choose a point R on l . Without changing the compasses opening, place the pointer on R .

Step 4 : Swing an arc that cuts l at a point S . Now \overline{RS} is a copy of \overline{PQ} .

6. Draw any line segment \overline{AB} . Mark any point M on it. Through M , draw a perpendicular to \overline{AB} . (Use ruler and compasses)

Steps of construction:

Step 1 : Draw a line segment \overline{AB} . Mark a point M on it.

Step 2 : With M as centre and a convenient radius, construct an arc intersecting the line segment \overline{AB} at two points P and Q .

Step 3 : With P and Q as centres and radius greater than PM , construct two arcs, which cut each other at R .

Step 4 : Join \overline{RM} . Then $\overline{RM} \perp \overline{AB}$.

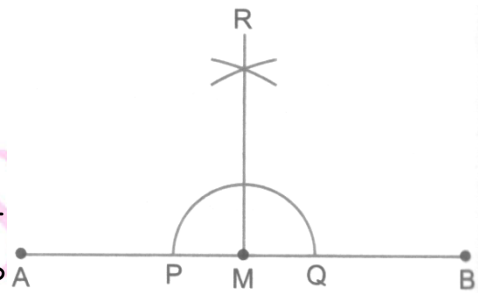

7. Draw any line segment \overline{PQ} . Take any point R not on it. Through R , draw a perpendicular to \overline{PQ} . (Use ruler and set-square)

Steps of construction:

Step 1 : Draw a line segment \overline{PQ} and take a point R outside it.



Step 2 : Place a set-square on \overline{PQ} such that one arm of its right angle aligns along \overline{PQ} .

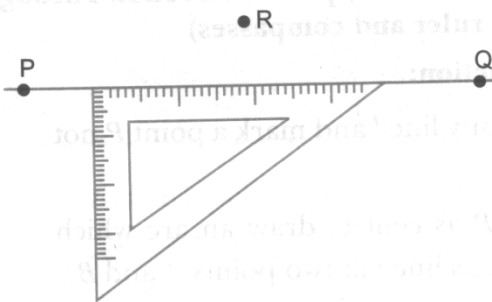

Step 3 : Place a ruler along the edge opposite to the right angle of the set-square.

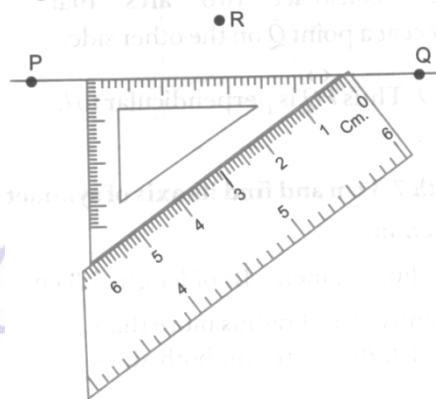

Step 4 : Hold the ruler fixed. Slide the set-square along the ruler till the point R touches the other arm of the set-square.

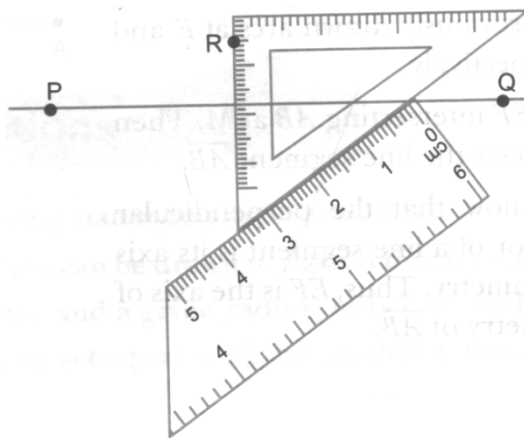

Step 5 : Join RM along the edge through R meeting \overline{PQ} at M.

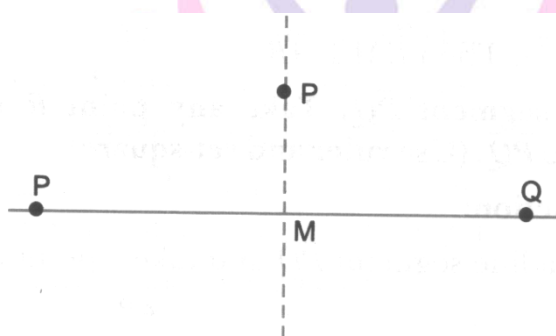

Now, $\overline{RM} \perp \overline{PQ}$.

8. Draw any line and take any point P not on it. Through P, draw a perpendicular to the given line. (Use ruler and compasses).

Step of construction:

Step 1 : Draw any line l and mark a point P not on it.

Step 2 : With P as centre, draw an arc which intersects line l at two points A and B.

Step 3 : Using the same radius and A and B as centres, construct two arcs that intersect at a point Q on the other side.

Step. Join PQ. Thus \overline{PQ} is perpendicular to l .

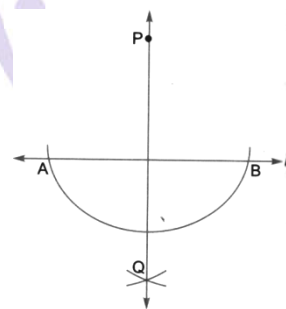

9. Draw \overline{AB} of length 7.3 cm and find its axis of symmetry.

Steps of construction:

Step 1 : Draw a line segment \overline{AB} of length 7.3 cm.

Step 2 : With centre A and radius more than half of AB, draw arcs on both sides of \overline{AB} .

Step 3 : With B as centre and the same radius as before, draw arcs, cutting the previously drawn arcs at E and F respectively.

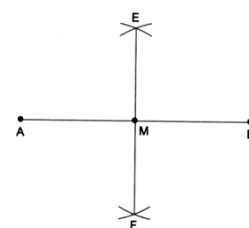

Step 4 : Join EF intersecting \overline{AB} at M. then M bisects the line segment \overline{AB} .

We know that the perpendicular bisector of a line segment is its axis of symmetry. Thus, EF, is the axis of symmetry of \overline{AB} .

10. Draw $\angle BAC$ of measure 75°

Step of construction:



Step 1 : Draw a ray \overline{AB} .

Step 2 : Place the centre of the protractor at A and the zero edge along \overline{AB} .

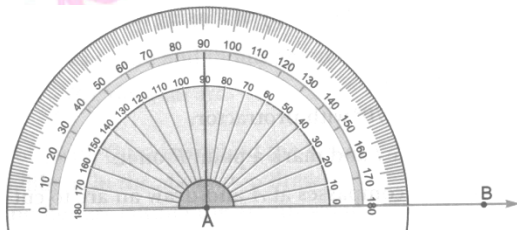

Step 3 : Start with zero near B, mark point C at 40° .

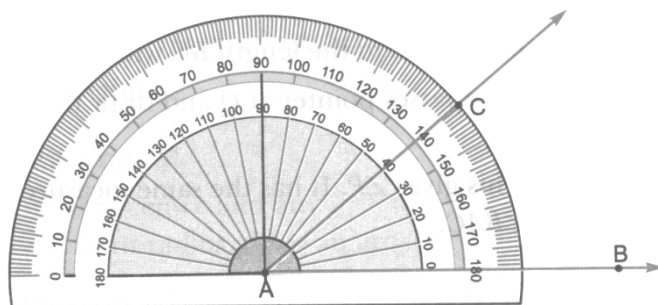

Step 4 : Join AC. $\angle BAC$ is required angle.

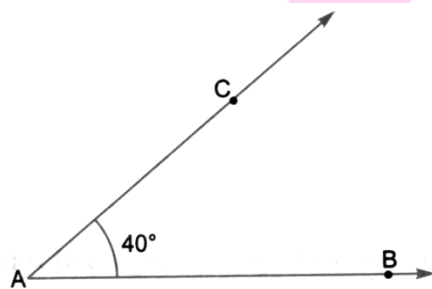

I. Long Answer Type Questions

1. Draw two concentric circles with centre O. mark a point.

- a. P which lies in the exterior of both the circle.
- b. Q which lies in the exterior of the inner circle and interior of the outer circle.
- c. R which lies in the interior of both the circle.

Suppose we construct two concentric circles with centre 'O' having radii 4 cm and 5 cm respectively.

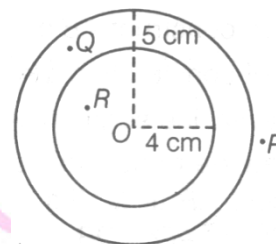

Steps of Constructions:

- a. For circle of radius of 4 cm
 - i. Open the compasses of the required radius of 4 cm by putting the pointer on O and opening the pencil upto 4 cm.
 - ii. Place the pointer of the compasses at O.
 - iii. Turn the compasses slowly to draw the circle.
- b. For circle of radius 5 cm
 - i. Open the compasses of the required radius of 5 cm.
 - ii. Mark a point 'O'. Place the pointer of the compasses at o.
 - iii. Turn the compasses slowly to draw the circle.

2. Draw a circle of $r = 5$ cm. draw any chord AB not passing through the centre. Draw the bisector of chord AB. Is it passing through the centre?

Steps of construction are as follows:

Step I Draw a circle with radius 5 cm.

Step II draw a chord AB.

Step III Draw the bisector of the chord AB, which intersect AB at R and passing through the centre of the circle 'O'.

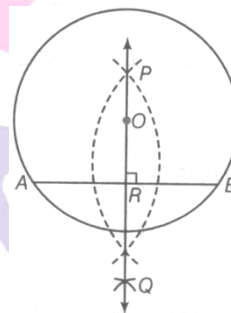

3. Construct PQ of length 9 cm. From this, cut off \overline{PA} of length 4.2 cm. Now, find the length of \overline{QA} ?

First of all, we construct \overline{PQ} of length 9 cm.

Now, steps of construction are as follows.

Step I Place the zero mark of the ruler at P.

Step II Mark pointy Q at a distance 9 cm from P.

Step III Mark another point A between P and Q and at distance 4.2 cm from P, such that $PA = 4.2$ cm.

Step IV Measure the line segment \overline{QA} .

We find that $\overline{QA} = 4.8$ cm.

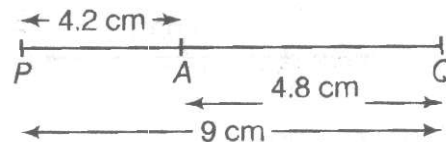

4. Draw a line segment $\overline{AB} = 12$ cm. using compasses, divided it into four equal parts.

Verify by actual measurement.

First of all, we construct $\overline{AB} = 12$ cm

Now, steps of construction are as follows:

Step I Draw a line segment $\overline{AB} = 12$ cm.

Step II Draw perpendicular bisector of \overline{AB} , which meets \overline{AB} at O . (i.e. O is the mid-point of \overline{AB}), i.e. $AO = OB$

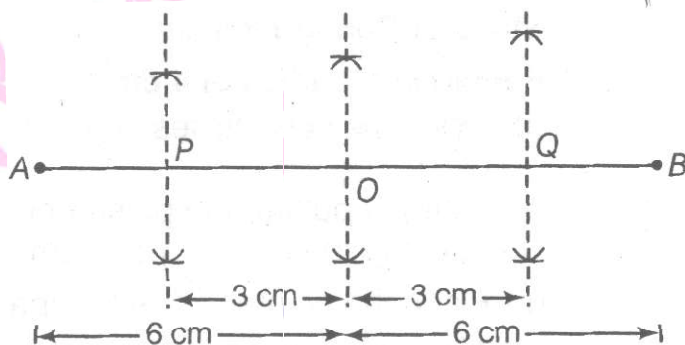

Step III Now, draw perpendicular bisector of \overline{AO} , which meet \overline{AB} at P such that $AP = PO$.

Step IV Then, draw perpendicular bisector of \overline{BO} , which meet \overline{AB} at Q such that $BQ = OQ$.

Step V the line segment \overline{AB} is divided into 4 equal parts at P, O and Q .

Step VI By actual measurement, we have

$$\overline{AP} = \overline{PO} = \overline{OQ} = \overline{QR} = 3 \text{ cm.}$$

5. Draw an angle of measure 75° . Make a copy of it using only straight edge and compasses. Steps of construction are as follows:

Step I First of all, construct an angle i.e. $\angle ABC = 75^\circ$, using protactor.

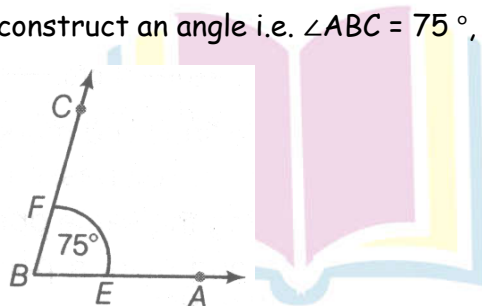

Step II Draw any line segment \overline{PQ} .

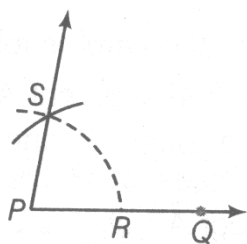

Step III With centre B and a suitable radius draw an arc which intersects \overline{BA} and \overline{BC} at E and F respectively.

Step IV Keeping the same radius and with centre as P, draw an arc intersecting \overline{PQ} at R.

Step V With centre R and radius equal to EF, draw an arc intersecting the previous arc at S.

Step VI Join PS and produce it.

Thus, $\angle QPS$ is the copy of $\angle ABC = 75^\circ$.

6. A farmer wants to divide a sugarcane of 9 ft length between his son and daughter equally. Divide it geometrically, considering sugarcane as a line of 9 cm. Using construction,

- Find the length of each part.
- Which values are depicted here?

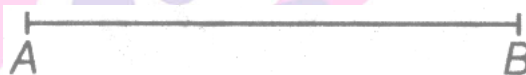

Steps of construction are as follows:

Step I Draw a line segment $\overline{PQ} = 9$ cm.

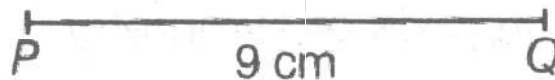

Step II With P as centre and a convenient radius (more than $\frac{1}{2}\overline{PQ}$), draw arc.

Step III With Q as centre and same radius, draw another arc such that it intersects the previous arc at A and B.

Step IV Join A and B.

Thus, \overline{AB} is perpendicular bisector of \overline{PQ} .

i.e. $OP = OQ = 4.5$ cm.

- Length of each part is 4.5 ft.

- The value depicted here is gender equality.

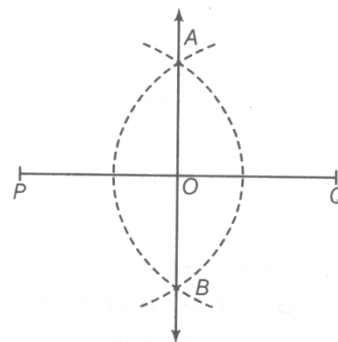
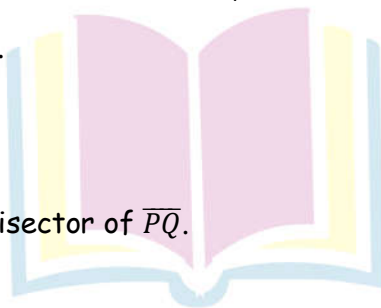

7. Draw an $\angle ABC$ of measure 45° , using ruler and compasses. Now, draw an $\angle DBA$ of measure 30° , using ruler and compasses as shown in figure. What is the measure of $\angle DBC$?

To draw an angle, we use following steps of construction.

Step I Draw a line segment BC of any length.

Step II Place the compasses pointer at B and draw a right angle (90°).

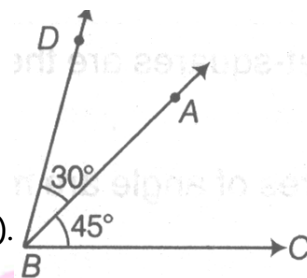
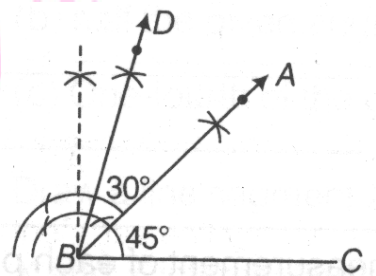

Step III Draw the angle bisector of the right angle such that $\angle ABC = \frac{1}{2}(90^\circ) = 45^\circ$.

Step IV Place the compasses pointer at B and draw an angle of 30° on the base BA ($\angle DBA$).

Step V By the help of protractor, we get $\angle DBC = 75^\circ$.

8. Draw an angle of measure 80° , using a protractor and divide it into four equal parts, using ruler and compasses. Check your construction by measurement.

Here, to divide an angle of measure 80° into four equal parts, we use the following steps of construction:

Step I Draw \overline{AB} of any length. Place the centre of the protractor at A and the zero edge along \overline{AB} .

Step II Start with zero near B and mark C at 80° .

Step III Join Ac , then $\angle BAC$ is an angle of measure 80° .

Step IV With A as centre and using compasses, draw an arc that cuts both rays of $\angle A$ at P and Q .

Step V With P as centre, draw (in the interior of $\angle A$) an arc, whose radius is more than half the length of PQ .

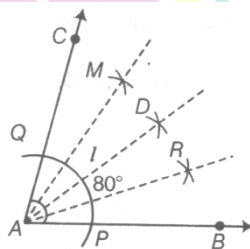

Step VI With the same radius with Q as centre, draw another arc in the interior of $\angle A$. Let the two arcs intersect at D . Join \overline{AD} , cutting arc PQ at I . Then, \overline{AD} divides the $\angle BAC$ into two equal parts.

Step VII Now taking P and I as centre, having radius more than half of length PI, draw two arcs respectively, which cut each other at R.

Step VIII Join \overline{AR} , which divides $\angle BAD$ into two equal parts.

Step IX Now, taking Q and I as centre, having radius more than half of length QI, draw two arcs respectively, which cut each other at M.

Step X Join $\angle AM$, which divide $\angle CAD$ into two equal parts.

Thus, \overline{AM} , \overline{AD} and \overline{AR} divide $\angle BAC$ into four equal parts.

II. Long Answer Type Questions

1. Draw an angle of 80° . Using a protractor and divide it into four equal parts, using ruler and compasses. Check your construction by measurement.

Here, to divide an angle of measure 80° into four equal parts, we use the following steps of construction

Step I : Draw \overline{AB} of any length. Place the centre of the protractor at A and the zero edge along \overline{AB} .

Step II : Start with zero near B. Mark C at 80°

Step III : Join AC, then $\angle BAC$ is an angle of measure 80° .

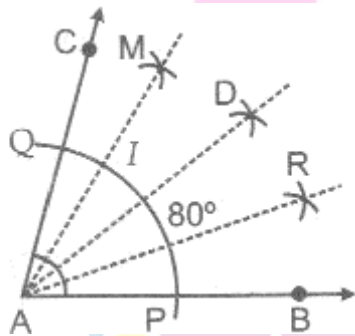

Step IV : With A as centre and using compasses, draw an arc that cuts both rays of $\angle A$ at P and Q.

Step V : With P as centre, draw (in the interior of $\angle A$) an arc whose radius is more than half the length of PQ.

Step VI : With the same radius with Q as centre, draw another arc in the interior of $\angle A$. Let the two arcs intersect at D. Join \overline{AD} , which cuts the arc PQ at I. Then, \overline{AD} divides the $\angle BAC$ in two equal parts.

Step VII : Now taking P and I as centre, having radius more than half of length I, draw two arcs respectively, which cut each other at R.

Step VIII : Join \overline{AR} . Then, divide $\angle BAD$ into two equal parts.

Step IX : Now taking Q and I as centre, having radius more than half of length QI , draw two arcs respectively, which cut each other at M .

Step X : Join \overline{AM} . Then, divide $\angle CAD$ into two equal parts.

Thus, \overline{AM} , \overline{AD} and \overline{AR} divide $\angle BAC$ into four equal parts.

2. Draw an angle of 60° , using ruler and compasses and divide it into four equal parts. Measure each part.

To draw an angle of 60° , using ruler and compasses, we use the following steps of construction:

Step I : Firstly, draw a line segment AB of any length.

Step II : Place the compasses pointer at point A and draw an angle of 60° by the help of ruler and compasses.



Step III : Place the pointer at point A and bisect the angle.

Step IV : Either side of bisected angle is also bisected by the help of ruler and compasses.

Step V : Measure the bisected angles with the help of protractor, each comes out to be of 15° .

3. Draw an $\angle ABC$ of measure 45° , using ruler and compasses. Now, draw an $\angle DBA$ of measure 30° , using ruler and compasses as shown in figure. What is the measure of $\angle DBC$.

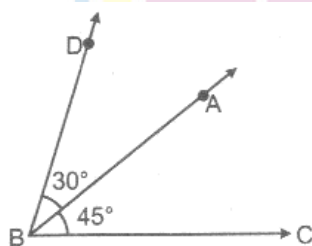

To draw an angle, we use following steps of construction:

Step I : Draw a line segment BC of any length.

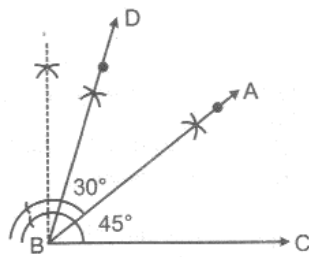

Step II : Place the compasses pointer at B and draw a right angle (90°).

Step III : Right angle (90°) is also bisected in 45° ($\angle ABC$) by the help of ruler and compasses.

Step IV : Place the compasses pointer at B and draw an angle of 30° ($\angle DBA$) between the right angle and bisected angle.

Step V : By the help of protractor, we get $\angle DBC = 75^\circ$.

4. Draw any angle with vertex O. Take a point A on one of its arms and B on another such that $OA = OB$. Draw the perpendicular bisector of \overline{OA} and \overline{OB} . Let them meet at

P. Is $PA = PB$?

Steps for Construction :

Step I : Firstly draw any angle XOY.

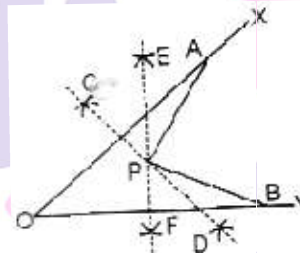

Step II : Take a point A on OX and a point B on OY such that $OA = OB$.

Step III : Draw CD and EF , the perpendicular bisector of $OA = OB$ respectively. Let them meet at P. $PA = PB$.

III. Long Answer Type Questions

1. State whether the following statements are true or false.

- (i) Two perpendiculars can be drawn to a given line from a point not lying on it.
- (ii) With a given centre and a given radius, only one circle can be drawn.
- (iii) Using only the two set-squares of the geometry box, an angle of 40° can be drawn.
- (iv) It is possible to draw two bisectors of a given angle.
- (v) With ruler and compasses, we can bisect any given line segment.
- (vi) An angle of 165° cannot be constructed with ruler and compasses.
- (vii) With ruler and compasses, any angle can be bisected.

(viii) Only one perpendicular bisector.

Sol. i. False

ii. True

iii. False

iv. False

v. True

vi. False

vii. True

viii. False

2. Draw an angle of 70° . Make a copy of it using only a straight edge and compasses.

Steps of construction:

Step 1 : Draw $\angle A = 70^\circ$ with protractor.

Step 2 : Draw a line l and mark a point P on it.

Step 3 : Place the compasses at A and draw an arc to cut the rays of $\angle A$ at B and C .

Step 4 : Use the same compasses pointer at Q and draw the arc to cut that arc drawn earlier in R .

Step 5 : Set your compasses to the length BC with the same radius.

Step 6 : Place the compasses pointer at Q and draw the arc to cut the arc drawn earlier in R .

Step 7 : Join PR . This gives $\angle P$. It has the same measure as $\angle A$. Thus, $\angle QPR = \angle BAC$.

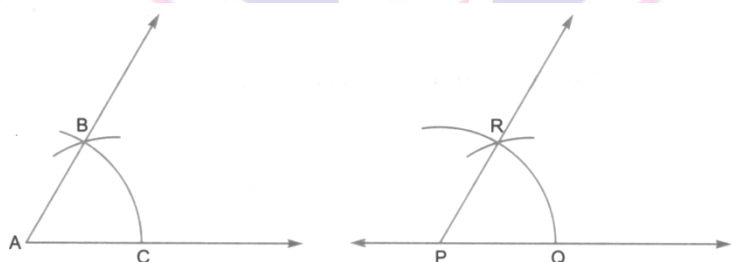

3. Construct with ruler and compasses angles of following measures:

(i). 60°

(ii) 30°

(iii) 90°

(iv) 45°

(v) 120°

i. Steps of construction:

Step 1 : Draw a ray \overrightarrow{OA} .

Step 2 : With centre O and any radius draw

an arc PQ with the help of compasses, cutting the ray \overrightarrow{OA} at P .

Step 3 : With centre P and the same radius, draw another arc cutting the arc PQ at R .

Step 4 : Join OR and produce it to obtain ray \overrightarrow{OB} . The angle $\angle BOA$ so obtained is the angle of measure 60° .

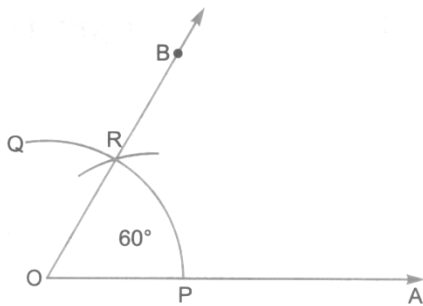

ii. Steps of construction:

Step 1 : Draw $\angle BOA = 60^\circ$ by using the steps mentioned above.

Step 2 : With centre O and any convenient radius draw an arc cutting OA and OB at P and Q respectively.

Step 3 : With P as centre and radius greater than $\frac{1}{2} PQ$ draw an arc.

Step 4 : Now, with Q as centre and the same radius as in the above step draw another arc cutting the arc drawn in step 3 at R .

Step 5 : Join O and R and draw ray \overrightarrow{OR} . Thus, $\angle AOR$ is the required angle of 30° .

iii. Steps of construction:

Step 1 : Draw a ray \overrightarrow{OA} .

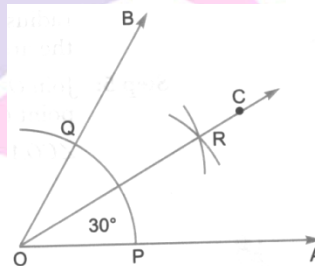

Step 2 : With O as centre and any convenient radius, draw an arc, cutting \overrightarrow{OA} at P .

Step 3 : With P as centre and the same radius, draw an arc cutting the arc drawn in above step at Q .

Step 4 : With Q as centre and the same radius as in above two steps, draw another arc, cutting the arc drawn in step at R .

Step 5 : With Q as centre and the same radius, draw an arc.

Step 6 : With R as centre and the same radius, draw another arc, cutting the arc drawn in above step at B .

Step 7 : Join OB and produce it to C . $\angle COA$ is the angle of measure 90° .

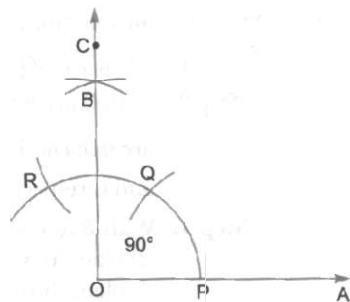

iv. Steps of construction

Step 1 : Draw $\angle BOA = 90^\circ$ by following the steps given above.

Step 2 : Bisect $\angle BOA$ with the help of compasses.

Step 3 : Draw OC , the bisector of $\angle AOB$. Thus, $\angle AOC = 45^\circ$.

v. Steps of construction:

Step 1 : Draw a ray \overrightarrow{OA} .

Step 2 : With O as centre and any convenient radius, draw an arc cutting \overrightarrow{OA} at P .

Step 3 : With P as centre and the same radius, draw an arc, cutting the first arc at Q .

Step 4 : With Q as centre and the same radius, draw another arc, cutting the arc drawn in step 2 at R .

Step 5 : Join OR and produce it to any point C .

$\angle COA$ as obtained is the angle of measure 120° .

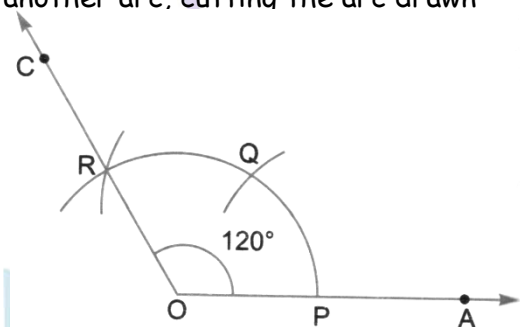
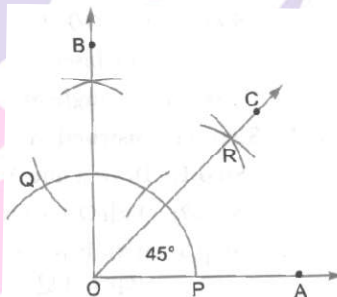

I. High Order Thinking Skills (HOTS)

1. How will you construct a 150° angle.

Steps for construction:

Step I : Firstly draw a line AB and make a point O on it.

Step II : With O as centre and any convenient radius, draw a semi-circle, cutting the line AB at I and S .

Step III : With P as centre and same radius draw an arc cutting the semi-circle at Q .

Step IV : With Q as centre and same radius, draw an arc cutting the semi-circle of step (ii) at R .

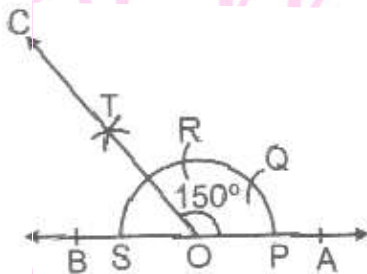

Step V : With centre R and radius is more than of SR draw an arc in the interior of SOR .

Step VI : With centre S and the same radius, as in step V. Draw an another arc intersecting the arc in step V at T .

Step VII : Join O to T and produce it to any point C .

Then $\angle AOC = 150^\circ$.

2. Construct and angle of $(22\frac{1}{2})^\circ$

Step of constructions:

Step I : Draw a line segment of AB of any length.

Step II : Make $\angle BAC = 90^\circ$

Step III : Draw angle bisector of $\angle BAC$, i.e., $\angle BAT = 45^\circ$

Step IV : Draw angle bisector of $\angle BAT$, i.e., $\angle TAS = \angle BAS = (22\frac{1}{2})^\circ$

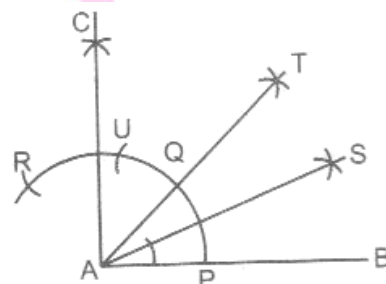

II. High Order Thinking Skills (HOTS)

1. Draw $\angle POQ$ of measure 75° and find its line of symmetry.

Steps of construction:

Step 1 : Draw $\angle POQ = 75^\circ$ with protractor.

Step 2 : With O as centre and using compasses, draw an arc that cuts both rays \overrightarrow{OP} and

\overrightarrow{OQ} of $\angle O$ at B and C respectively.

Step 3 : With B as centre, draw (in the interior of $\angle O$) an arc whose radius is more

than half the length BC.

Step 4 : With C as centre and with same radius, draw another arc in the interior of $\angle O$ intersecting the previous arc at D .

Step 5 : Join OD . Then \overrightarrow{OD} is the required bisector of $\angle O$. The bisector OD of $\angle POQ$ is the line of symmetry.

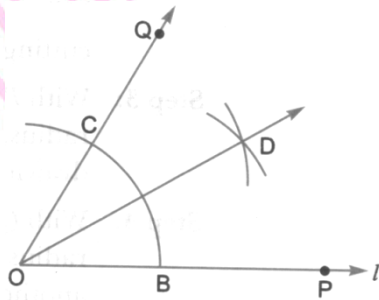

2. Construct an angle of 135° with ruler and compasses.

Steps of construction:

Step 1 : Draw a line AB .

Step 2 : With O as centre and any convenient radius, draw an arc, cutting OB on P .

Step 3 : With P as centre and the same radius, draw an arc cutting the arc drawn in step 2 at Q .

Step 4 : With Q as centre and the same radius as in step 2 and step 3, draw another arc, cutting the arc drawn in step 2 at R .

Step 5 : With Q as centre and the same radius, draw an arc.

Step 6 : With R as centre and the same radius, draw another arc, cutting the arc drawn in step 5 at C .

Join OB and produce it to C .

$\angle COA$ is the angle of measure 90° .

Step 7 : As $90^\circ + \frac{1}{2}(90^\circ) = 135^\circ$

$$\text{or } \angle BOC + \frac{1}{2} \angle AOC = 135^\circ$$

$$\angle BOC + \angle DOC = 135^\circ$$

$$\text{So, } \angle BOD = 135^\circ.$$

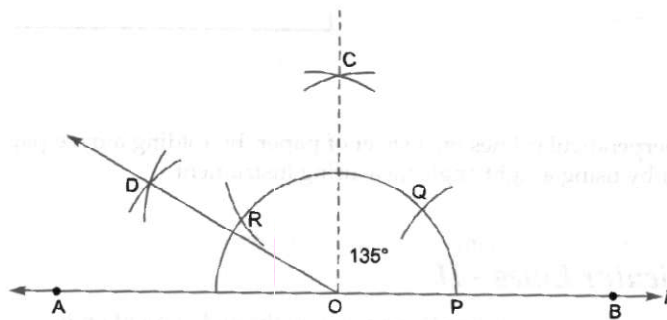

Value Based Questions

1. Draw a circle of radius 6 cm, using ruler and compass. Draw one of its diameters. Draw the perpendicular bisector of this diameter. Does this perpendicular bisector contain another diameter of the circle?

To draw a circle, we use the following steps of construction:

Step I : Firstly, draw a circle of radius 6 cm with the help of ruler and compasses.

Step II : Draw a diameter of 12 cm length in circle.

Step III : Place the compasses pointer at points A and B and draw an arc at A' and B' , Join $A'B'$ which intersects at P point of diameter.

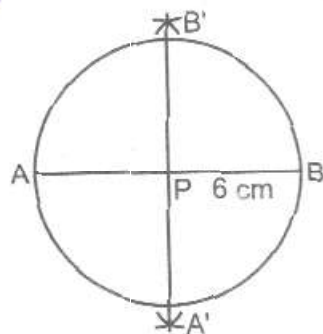

Thus, $A'B'$ is perpendicular of line segment AB . Hence, the same circle is also drawn by same length of diameter $A'B'$.